

DISCOM1

The DISCOM1 is a high quality production mixer for discotheques and radio stations. D&R's immense experience gained in building thousands of mixing desks has gone into this exciting new workhorse.

All the basic features are here. The two balanced low noise microphone inputs have especially designed equalisation electronics to improve the clarity of the human voice. A gain control adjusts the incoming signal to the internal working level. The creation of a moving sound can be realized by means of the pan pot. This control can sweep the mic signal from left to right and visa versa. The p.f.l. switch displays the incoming microphone level in the master led bar. A smooth running fader completes the mic channels. On the back of this superb looking mixer there is an insert in/output socket to add effects to your sound such as reverb, echo, flanging, chorussing etc.

The extremely low noise disc inputs are carefully designed R.I.A.A. corrected input stages. With the gain control, sensitivity can be adjusted to match any cartridge on the market. By using the p.f.l. switch you can place the stylus in the first groove of a disc recording without interrupting your performance (so that it is ready when you need it).

A great flexibility of the DISCOM1 lies in its phono inputs which can be switched to unbalanced microphone inputs, thus providing a 4 input microphone mixer together with 3 stereo tape inputs. These tape inputs have optimal sensitivity, low distortion and a generous gain range.

To continue with the fantastic features of the DISCOM 1 we'll continue with its comprehensive master section. This production mixer has an extremely fast eleven segment peak reading led bar, indicating every spike so you can protect your power amps and/or your tape machine/deck. The outgoing signals can be equalized independently to correct for room acoustics. It's a high quality three band equalizer which can handle any acoustics. On the very right side of the mixer is the stereo monitoring section. With this stereo control you can pre-fade listen to every stereo input independently to adjust the incoming signals.

On the back of the console, which is suitable for mounting in professional 19" racks, are the cinch in/outputs which accept all incoming signal levels.

SUMMARY

The DISCOM 1 has more facilities than any other discotheque mixer in its price range. The DISCOM 1 is very easy to service. For example, a fader can be replaced simply by the remove of two bolts. The name D&R is a guarantee of fine workmanship. The DISCOM1 mixer will satisfy even the most demanding user.

SPECIFICATIONS

■ microphone input	imp. 1 kOhm gain trim -64dBu to -20 dBu noise less than -126 dBu
■ equalizer	+16 dB at 10 kHz +12 dB at 1 kHz +16 dB at 100Hz
■ insert	prefader out at 100 ohm left/right buss in at 22kOhm
■ disc input	input imp. 47kohm gain trim 1 mV-10 mV at 1 kHz equalisation + 1 dB R.I.A.A. curve
■ tape input	imp. 10 kohm gain trim -10 dB to infinity
■ main output	imp. to drive 2 kohm and above level 0 dBu (max. +22dBu)
■ tape output	imp. to drive 4 kohm and above level -20 dBu
■ equalisation	+16 dB at 12 kHz +12 dB at 1 kHz +16 dB at 50 Hz
■ phones	to drive 600 ohm and above
■ remote outputs	for switching 24volt-250 mA
■ power supply	AC input 50/60 Hz 220 volt
■ Dimensions	483x280x90 mm
■ weight	4 kg

your dealer

We reserve the right to modify and /or improve our designs without prior notice.

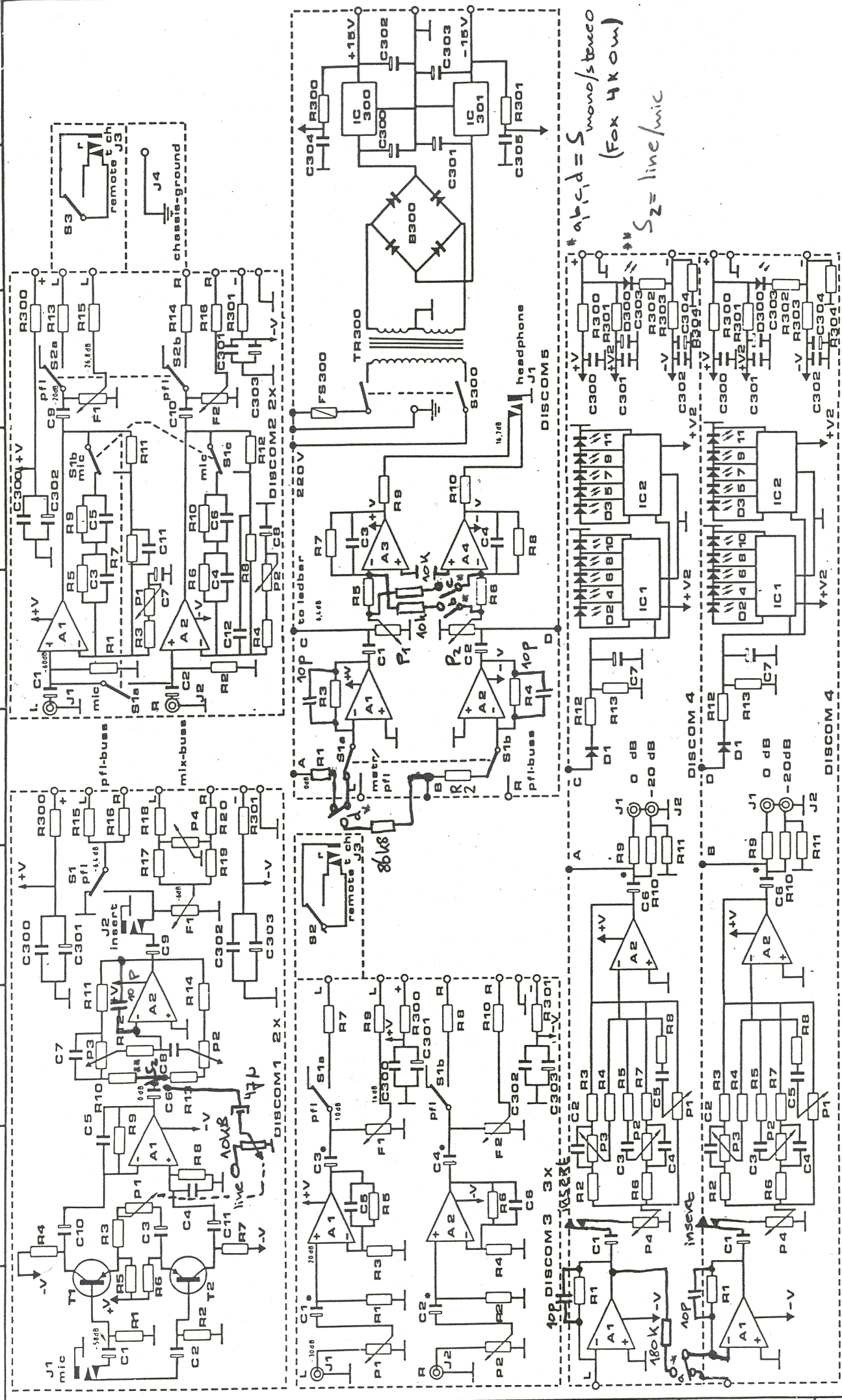

TITLE: **serie discom1**
 RIJNKADE 15b
 1382 GS WEESP
 PHONE: 02940 18014
 ELECTRONICA BV

SHEET 1 OF 1 © 1984
 DRAWN : gj turnhout
 DATE : 24-1-1986
 CHECKED:

P.C.B. INDEX: 1b, 2b, 3b, 4d, 5b
 NOTES: * R1-R6, C3-C6, A1+A2 added on 3b
 4d - for constant tape level connect
 * R10+R11 to C1-

DISCOM 5
 DISCOM 4
 DISCOM 4
 DISCOM 4

A	B	C	D	E	F	G	H	K	L
---	---	---	---	---	---	---	---	---	---

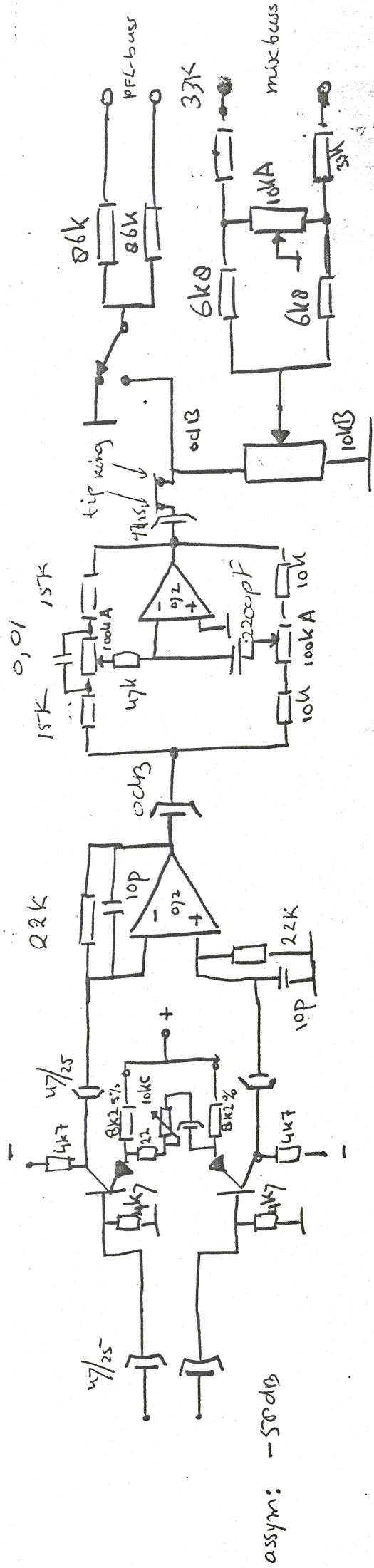

Mic input Discom 1

10mA von Ausgangsleistung

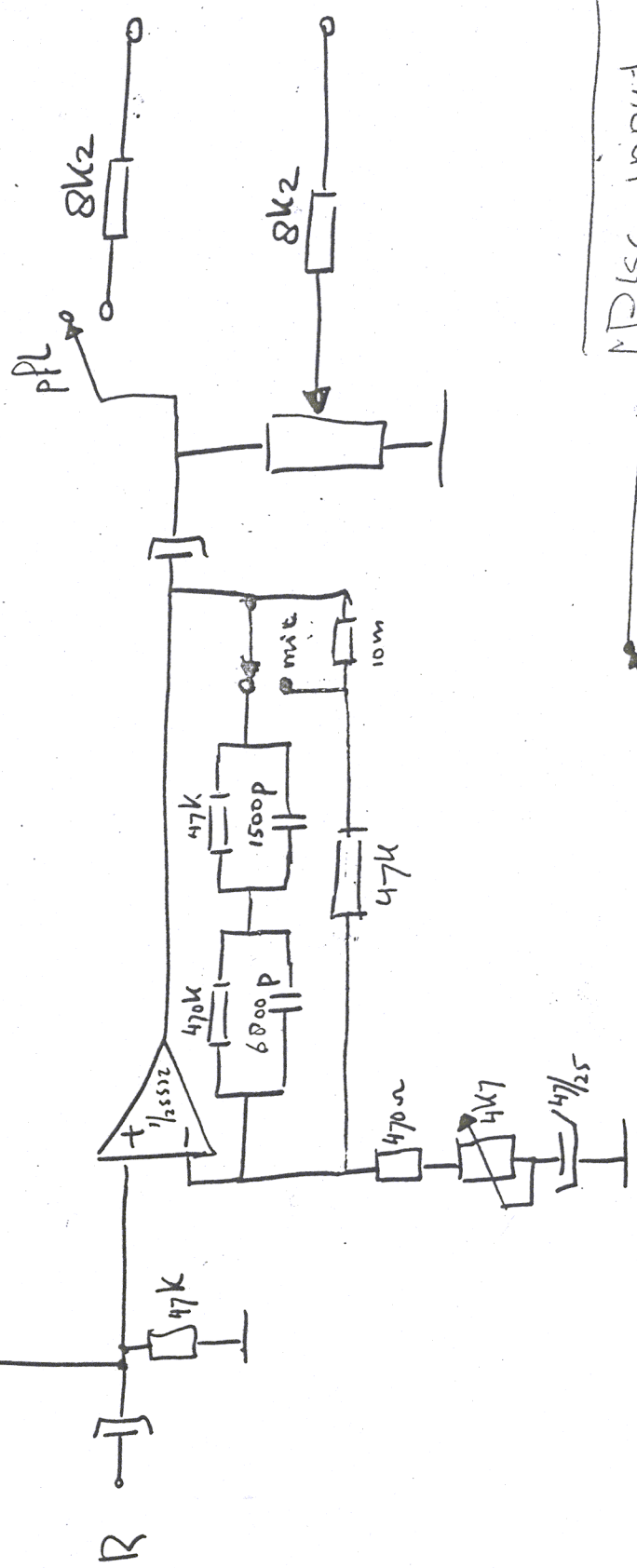
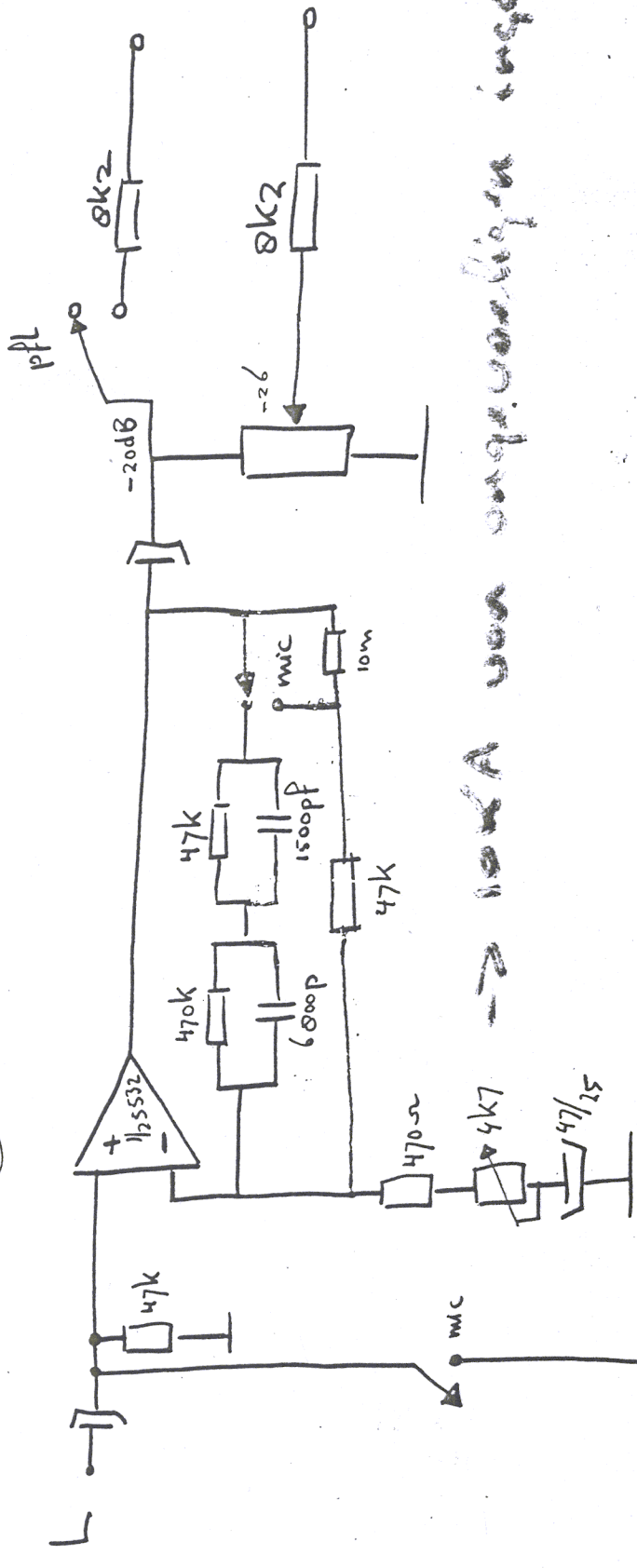

Disc input

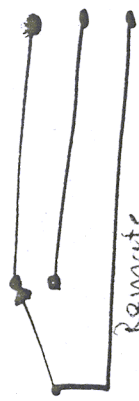

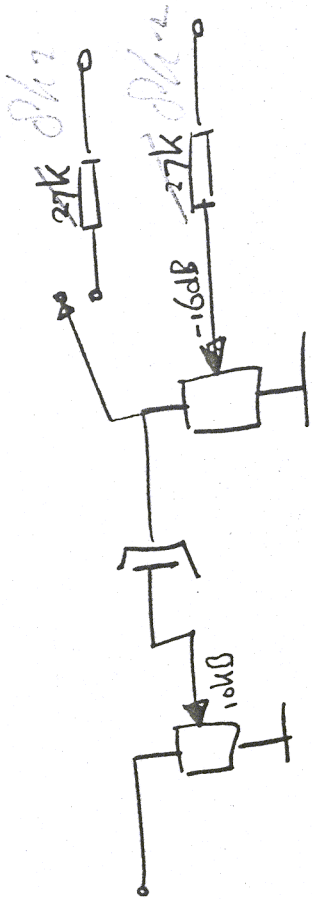
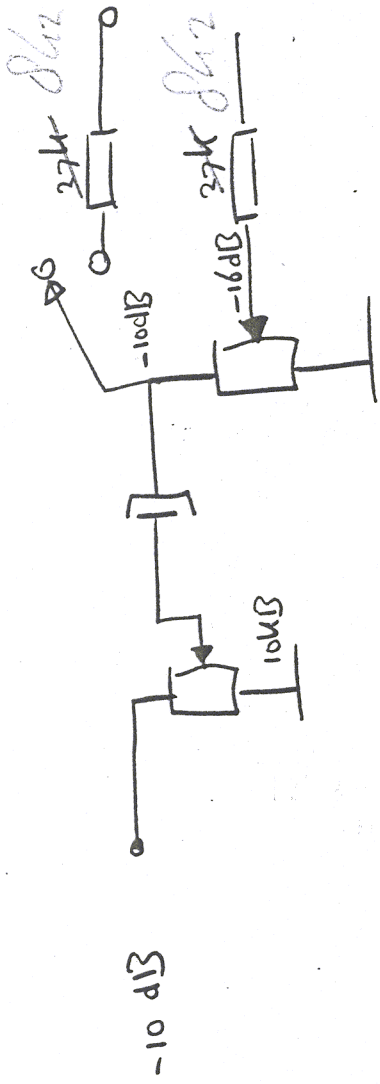

Tape input.

DISCOM-1B

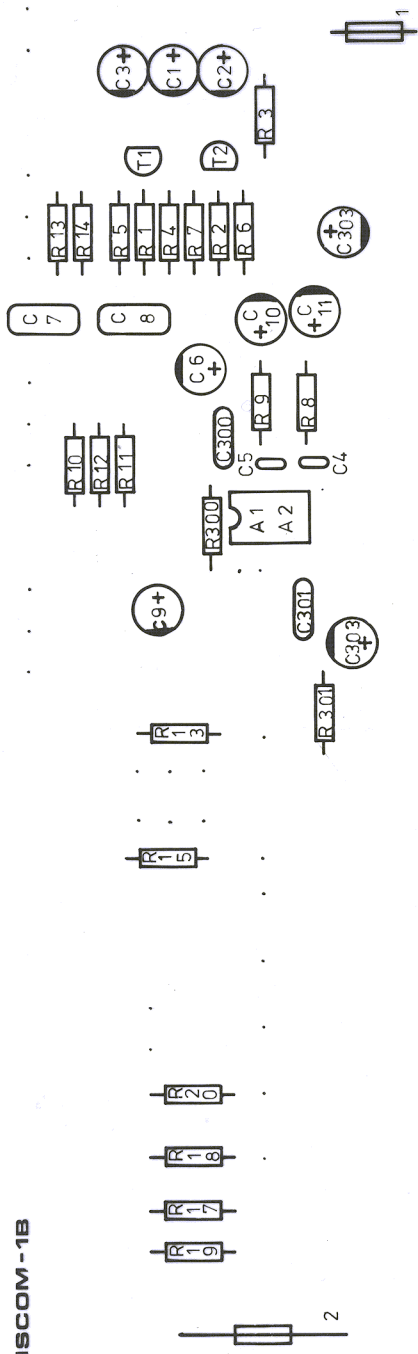

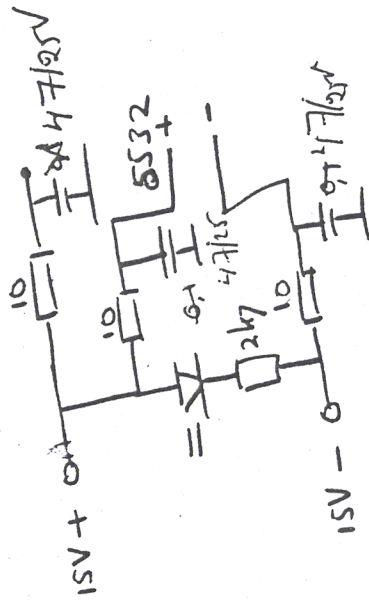
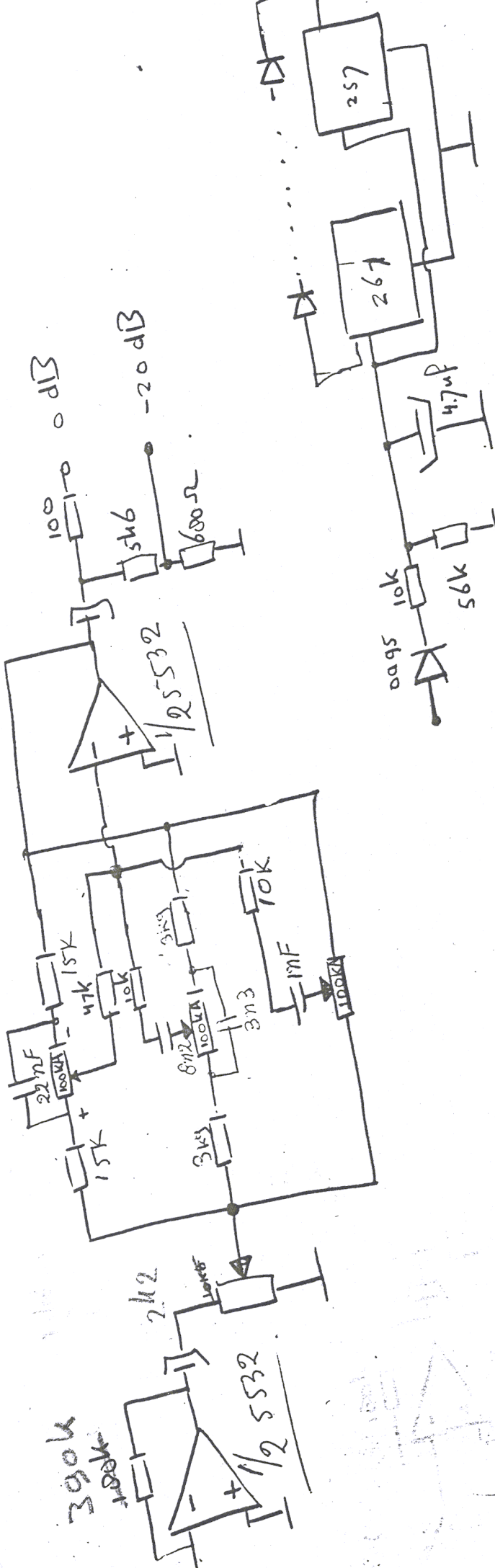

MASTER DISCOM.

DISCOM 2b

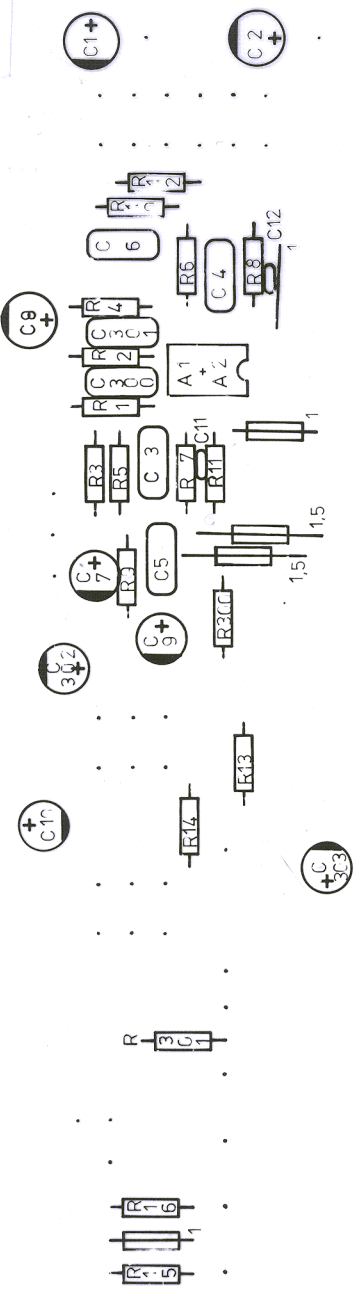

1,5
1,5
1

DISCOM 3 B

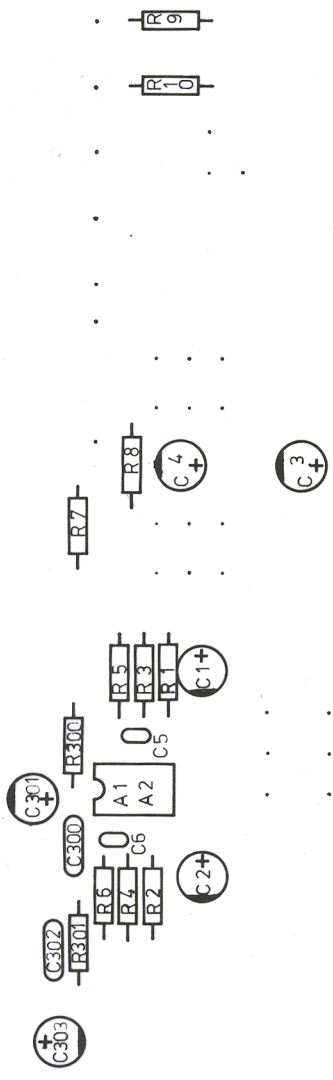

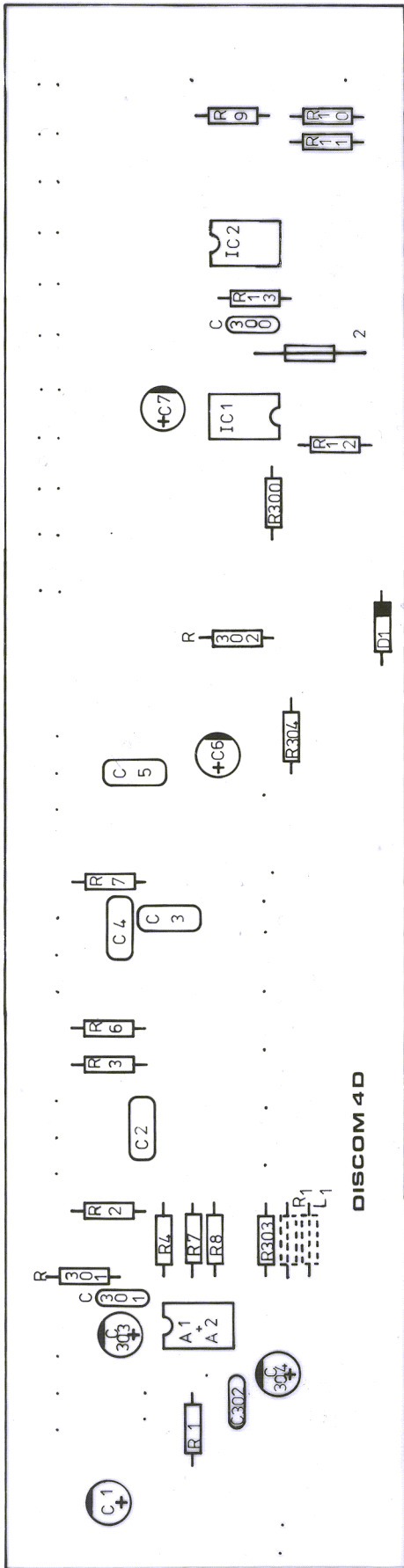

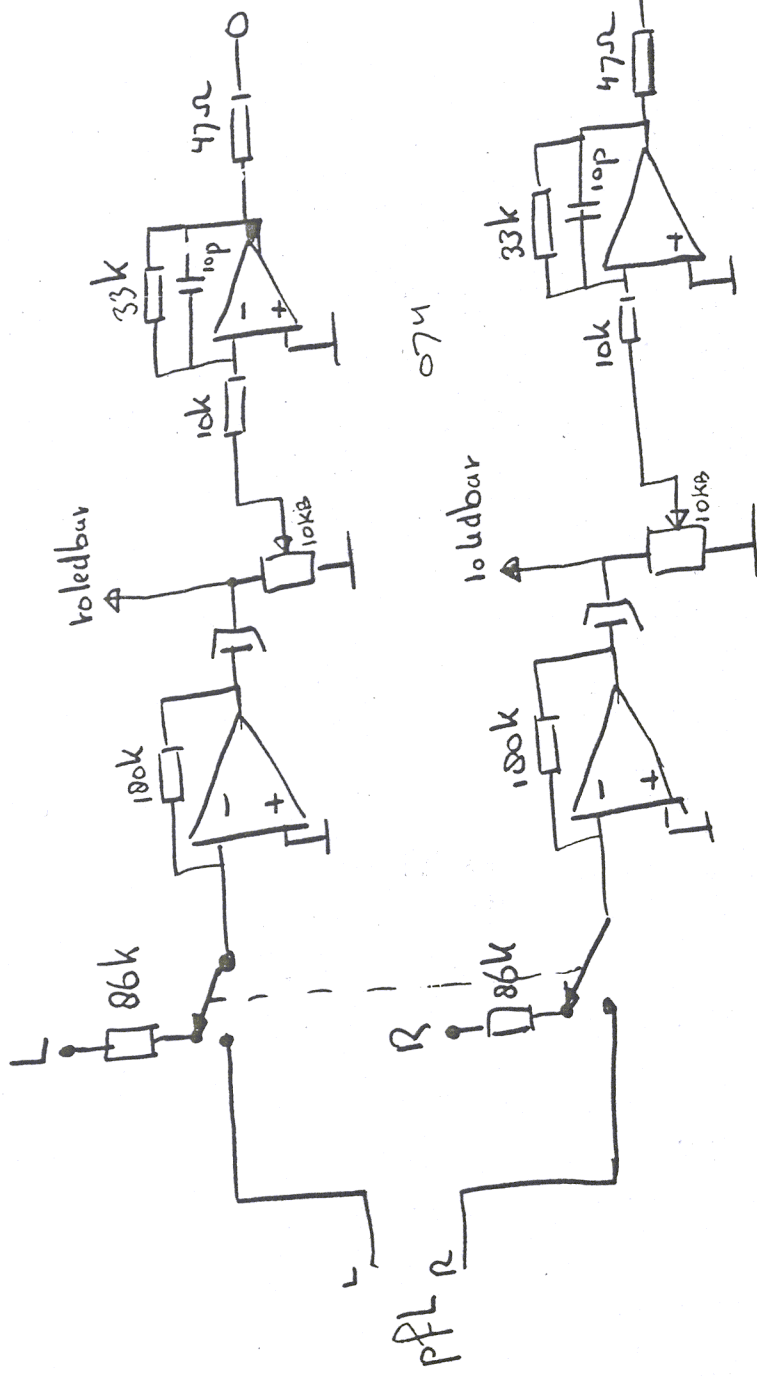

headphone

074

5 spannings van positieve
 A ← bij niet opskakelen van positieve

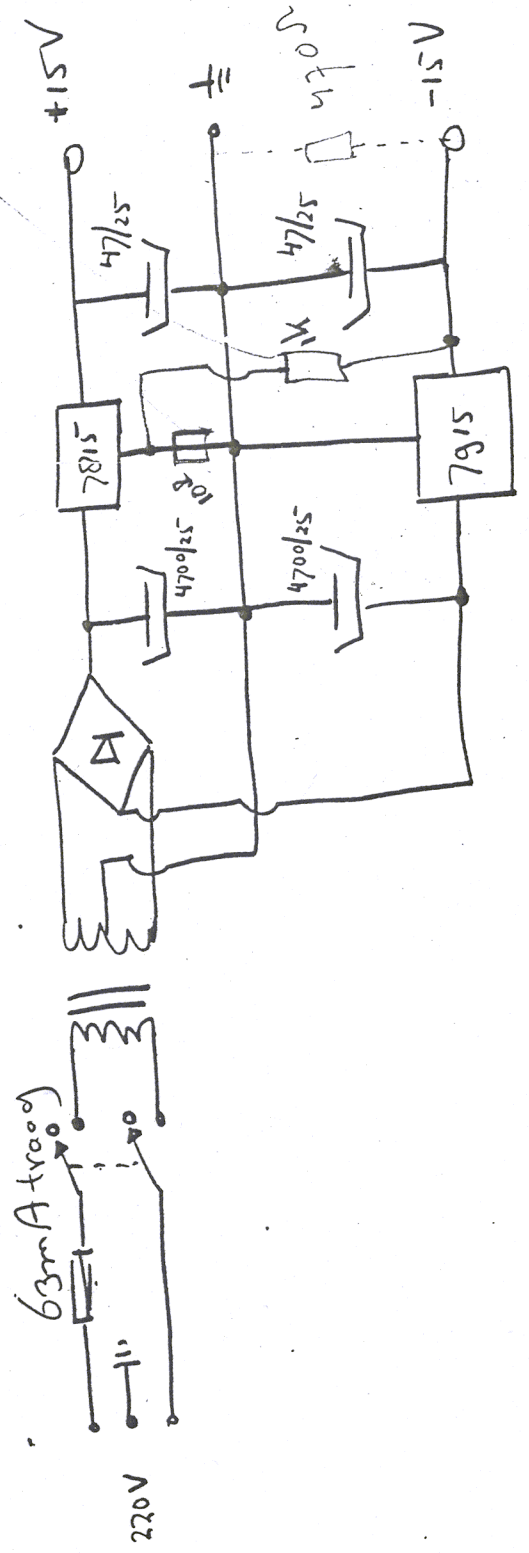

Maxster Discow
 Power supply

