

AIRMATE-USB FADERSTARTS OPTIONS.

The Airmate USB has fader start contacts (ground free) at the back in the form of jack connectors. To use those signals in your playout software, there must be an interface available between the Airmate and your PC.

Below is a block diagram of how the signal flow will look like:

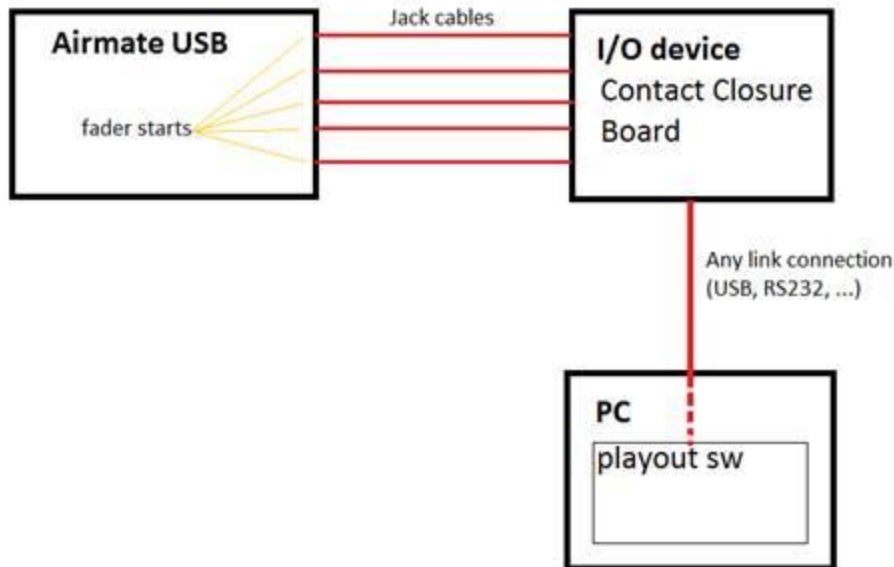

So, you need an interface for the Airmate-USB to be able to connect the fader start signals to your pc. There are a lot of devices (interfaces) available in the market that will do that for you. (see link below; Contact Closure Board).

If you will use for example a contact closure board, that will convert a contact closure to a serial command.

That serial command can be used by StationPlaylist to execute a function directly, or to execute a script which executes functions in a defined order (see manual).

I hope you understand a little bit better how communication works between Airmate and StationPlaylist.

From the StationPlaylist Studio manual:

Communications (Pro edition only)

Studio can communicate with peripheral devices via TCP communications, a serial port, serial contact closure board, and parallel ports on the computer.

Studio can control a peripheral device such as an audio switch, and a peripheral device can control *Studio*, such as a satellite receiver or broadcast console.

Contact Closure Board:

<http://techlogique.wordpress.com/2007/04/25/devices-that-make-a-difference-contact-closure-to-serial-the-programmable-gpicontact-closure-serial-interface-rgb-16-fp-from-rgb-spectrum/>

The GPI/Contact Closure Interface is a solution for translating contact closures into serial commands